

Aurora Design BTU Smart-3.2 / BTU-3.2 Bluetooth/USB AAC/MP3/Ogg/FLAC Adapter

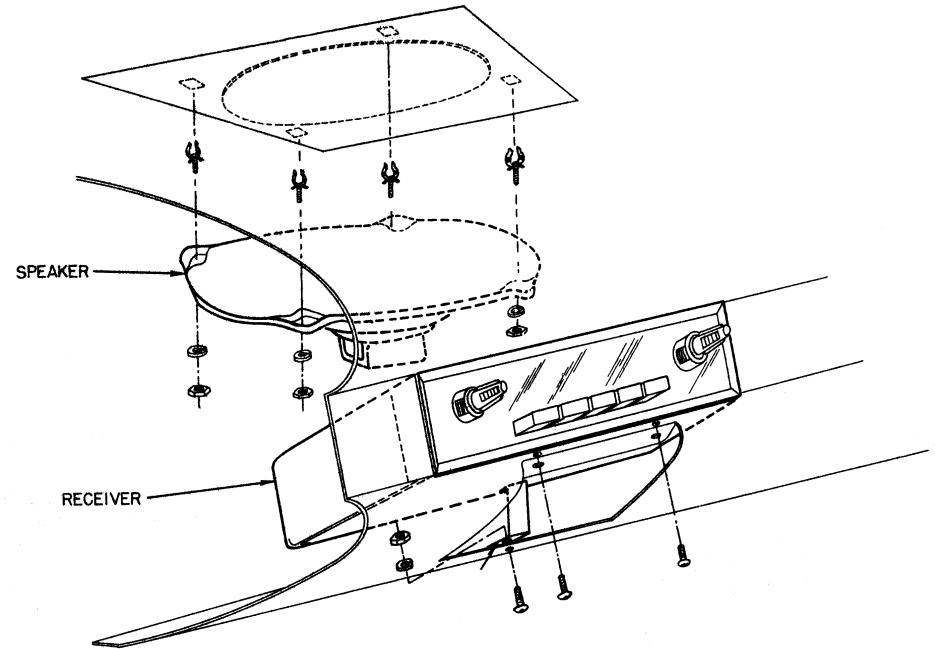

Never use a hand-held device while driving. Aurora Design LLC. assumes no responsibility for personal injury or property damage incurred due to hazardous driving as a result of interaction with the BTU-3.2 or other Bluetooth devices.

BE SAFE! Never text while driving or be distracted by the radio.

Note: *seek-button* refers to the Wonderbar or Town & Country button on a signal seeking radio. In AM/FM mode this button will only control the radio seek function, not the Bluetooth/USB.

Bluetooth® is a registered trademark of the Bluetooth SIG
AAC trademark used under license from Via Licensing
All other trademarks are those of their respective owners

Aurora Design LLC. ©2014-25 Rev 3.2.11 12/25

User Operation Manual



Specifications:

Bluetooth Transceiver*:

Frequency Band:	2.40-2.48GHz
Standard:	Bluetooth 5.0 certified, Class 2
Profiles- BTU Smart:	HFP 1.7.2, A2DP 1.3, AVRCP 1.6, MSBC
Profiles- BTU:	HFP 1.6, A2DP 1.2, AVRCP 1.5
Sensitivity:	-90dBm @ 0.1% BER
TX Power:	4dBm maximum

USB Interface:

SDP/CDP/DCP:	USB 2.0 (1.0 and 1.1 compatible) 2.1A maximum charging
---------------------	---

USB File System:

Supported Formats:	FAT12, FAT16, FAT32 MBR Primary partition only
Maximum Hierarchal Levels:	2 deep under root or ~Music~ folder
Maximum Root Folders:	250
Maximum Total Folders:	1800
Maximum Files/Folder:	250
Maximum Total Files:	65534
Supported File Formats:	.acc .m4a .mp3 ogg .flac

USB Decoder:

Maximum Rate:	48kHz AAC / 384kb/s 48kHz Ogg Vorbis / 500kb/s 48kHz FLAC / 1000kb/s 48kHz MPEG1-L3 / 320kb/s 24kHz MPEG2-L3 / 160kb/s
----------------------	--

Minimum Rate:

	8kHz AAC / 8kb/s 8kHz Ogg Vorbis / 8kb/s 8kHz FLAC / 75kb/s 32kHz MPEG1.0-L3 / 32kb/s 16kHz MPEG2.0-L3 / 8kb/s
--	--

Environmental:

Temperature:	-30C to 65C ambient (-22F to 150F) Operating -40C to 125C ambient (-40F to 257F) Storage
Humidity:	10% to 90% non-condensing

Congratulations on your new Aurora Design BTU Smart-3.2/BTU-3.2 Bluetooth/USB adapter. Combined with an FMR-3 converted radio, you can enjoy 21st century technology in your classic vehicle! This manual covers basic Bluetooth operation. For information on Smart features, refer to the *FMRConnect™* User manual. Note: The BTU-Smart and BTU modules will be referred to as BTU in this manual unless otherwise noted.

Setup: Your radio may have come equipped with an internal microphone. If not, before installing your radio back into your vehicle, you may wish to plug the hands-free microphone or optional illuminated pushbutton into the appropriate jacks on the radio. The microphone can be placed in a convenient location in the vehicle, typically along the front edge of the headliner near the rear view mirror or along the bottom edge of the dashboard. The attached cable is 9.8' (3M) long and can be routed as required, typically behind the A pillar cover for headliner mounting. Excess cable can be coiled and tied off.

Basic Operation: Operation of the BTU-3.2 is extremely simple yet powerful. The BTU-3.2, when combined with an FMR-3 AM/FM receiver form a fully integrated AM/FM/Bluetooth/BLE/USB AAC/MP3/OGG/FLAC solution. Communication over a proprietary com-link keeps the two modules in perfect sync. Full operation is provided by the existing controls on the radio or through the FMRConnect™ Mobile App on BTU Smart equipped radios. Additional control is provided through an optional pushbutton and the FMR Configurator™ Desktop App.

When streaming music or handling a phone call, the FMR-3 status LED will change color to indicate Bluetooth/USB operation. (see FMR-3 manual for more information on status LED) When you stop streaming music or end a call, the BTU-3.2 will put the FMR-3 back into normal operation. Everything is handled automatically.

The BTU-3.2 supports SBC and AAC formats over Bluetooth and AAC, MP3, Ogg Vorbis and FLAC formats over USB. AAC files offer higher quality than MP3 and is the native format used by iTunes® and many other popular music services. AAC files will play natively off compatible Bluetooth devices and can be copied directly onto USB drives for playback.

Since the BTU-3.2 contains both Bluetooth and USB interfaces, control of the module focuses on one interface at a time. Just as with a computer, the application that currently has focus receives the inputs from the keyboard and mouse, so do the Bluetooth and USB interfaces on the BTU-3.2. If only one interface is active, for example Bluetooth connected and no USB drive attached, the controls will affect the Bluetooth interface. Likewise if a USB drive is attached and no Bluetooth device is connected, the controls will affect the USB interface. In the case where both a Bluetooth device is connected and a USB drive is attached, the one that is currently active will have focus from the controls. If neither interface is currently active, the BTU-3.2 will focus control on the USB interface by default. In this case to

*Characterized by component manufacturer

change focus to the Bluetooth device, momentarily remove the USB drive or start playback using the menus on the Bluetooth device.

The BTU-3.2 will always return to the last mode it was in when the radio was turned off assuming the Bluetooth or USB devices are still present. For example, if the BTU-3.2 was playing back from the Bluetooth or USB when the radio was powered off, it will return to playing back from where it left off when the radio is turned back on. Additionally, if a USB drive is inserted after the the radio is turned on, the BTU-3.2 will start playback of the USB drive unless the Bluetooth interface is currently active.

The BTU-3.2 supports Enhanced *Voice Assist HD* which will clearly speaks messages to you to assist in the operation of the radio.

Bluetooth Pairing: To pair a new device, twist the volume control back and forth twice towards the direction of higher volume or push and hold the optional pushbutton. The optional front panel status LED or the pushbutton LED will flash and a *Voice Assist HD* message will be heard in the radio. The BTU-3.2 will then go into pairing mode for approximately 60 seconds or until a device is paired. While in pairing, the BTU-3.2 will display as *AuroraDesign BTU-x.x.x* in the Bluetooth section of your device. (x.x.x represents the version) Select the BTU-3.2 to connect. (refer to the owners manual for your Bluetooth device for information on pairing) If you wait longer than 60 seconds the BTU-3.2 will time out and *Voice Assist HD* message will be heard. Up to eight devices can be paired to the BTU-3.2.

After pairing, select the desired options on the phone. For iPhones™ select the ⓘ icon and set the Device Type to Car Stereo. For Android™ phones, select the ⚙️ and set the Calls and Audio as desired.

For pairing the BTU Smart-3.2 to the FMR Connect™ Mobile App, while pairing is open as outlined above, open the App and select the Radios tab. On the Radios page, select the Add button. The App will then pair and bond to the radio. This can be done before or after the above pairing. For more information about FMRConnect™ please refer to its User Manual.

Bluetooth Connecting: The BTU-3.2 will automatically attempt to reconnect to the last connected Bluetooth device. If this device is not within range, the BTU-3.2 will then attempt to reconnect to any of the last four connected devices. This is handy when the user has multiple Bluetooth devices, or several people use the radio. If any paired device is within range when the radio is powered on, the BTU-3.2 will reconnect and return to its last mode. The optional front panel LED or the optional pushbutton LED will illuminate to signify a Bluetooth device is connected. A *Voice Assist HD* message will also be heard in the radio when a Bluetooth device successfully connects.

Bluetooth Name: To change the name of the BTU-3.2 from the default *AuroraDesign BTU-x.x.x* to something more personal and easier to

radio or television reception, which can be determined by turning the equipment off and on, the user is encouraged to try to correct the interference by one or more of the following measures:

- Reorient or relocate the receiving antenna.
- Increase the separation between the equipment and receiver.
- Consult the dealer or an experienced radio/TV technician for help.

European Bluetooth Certification:

The Bluetooth module used in this device complies with the essential requirements of the R&TTE 1999/EC, the EMC Directive 2004/108/EC and the low-voltage Directive 2006/95/EC.

Canadian Bluetooth Certification:

IC: 12246A-BM62S2 (BTU Smart)

IC: 12246A-BM20SPKS1 (BTU)

This device complies with Industry Canada license-exempt RS standard(s). Operation is subject to the following two conditions: (1) this device may not cause interference, and (2) this device must accept any interference, including interference that may cause undesired operation of the device.

Under Industry Canada regulations, this radio transmitter may only operate using an antenna of a type and maximum (or lesser) gain approved for the transmitter by Industry Canada. To reduce potential radio interference to other users, the antenna type and its gain should be so chosen that the equivalent isotropically radiated power (e.i.r.p.) is not more than that necessary for successful communication.

Le présent appareil est conforme aux CNR d'Industrie Canada applicables aux appareils radio exempts de licence. L'exploitation est autorisée aux deux conditions suivantes: (1) l'appareil ne doit pas produire de brouillage, et (2) l'utilisateur de l'appareil doit accepter tout brouillage radioélectrique subi, même si le brouillage est susceptible d'en compromettre le fonctionnement.

Conformément à la réglementation d'Industrie Canada, le présent émetteur radio peut fonctionner avec une antenne d'un type et d'un gain maximal (ou inférieur) approuvé pour l'émetteur par Industrie Canada. Dans le but de réduire les risques de brouillage radioélectrique à l'intention des autres utilisateurs, il faut choisir le type d'antenne et son gain de sorte que la puissance isotrope rayonnée équivalente (p.i.r.e.) ne dépasse pas l'intensité nécessaire à l'établissement d'une communication satisfaisante.

Troubleshooting:

Poor Range: Make sure nothing is obstructing the dial face of the radio, or the openings along the bottom side of the radio chassis. Try moving your Bluetooth device to a different location.

No Sound: For Bluetooth, make sure the BTU-3.2 is paired and connected to your device. Also make sure the BTU-3.2 is selected as the audio device for streaming audio and hands-free operation on your device following the manufacturers instructions. Verify the audio levels are set properly on the Bluetooth device.

For USB, verify that the USB drive is formatted correctly and contains valid aac/m4a/mp3/ogg/flac audio files using the correct file extension.

Long Delays: Do not place many non-audio files on the USB drive. This will slow down indexing the drive.

If the BTU-3.2 is set to sequential playback and you skip songs/folders while the first song is playing, it may take a while for the next song to start playing if the indexing process has not yet completed.

The drive may have a corrupted file table. Reformat the drive as FAT32 and recopy your files onto the drive.

For best performance, connect blank drive to radio before copying music files to allow housekeeping files to be first ones on drive.

USB skipping: Make sure the FLASH drive is fast enough and defragmented. (FLAC/Ogg require a vey fast drive)

USB erratic operation: Reformat drive as FAT32 Primary partition.

Bluetooth Classic or Smart won't pair or connect: Try resetting the phone. If the issue persists follow the instructions in the QuickStart Guide to perform a full reset of the BTU module. Note: all previous pairings will be lost.

US Bluetooth Certification:

FCC ID: A8TBM62S2 (BTU Smart)

FCC ID: A8TBM20SPKXYNBZ (BTU)

This equipment has been tested and found to comply with the limits for a Class B digital device, pursuant to part 15 of the FCC Rules. These limits are designed to provide reasonable protection against harmful interference in a residential installation. This equipment generates, uses and can radiate radio frequency energy, and if not installed and used in accordance with the instructions, may cause harmful interference to radio communications. However, there is no guarantee that interference will not occur in a particular installation. If this equipment does cause harmful interference to

remember if you have multiple FMR/BTU radios (up to 32 characters long) like *Darryl's 64.5 Mustang*, use the FMRConnect™ Mobile App or the FMR Configurator™ Desktop App. Please refer to the user manuals for the App's for more information

Bluetooth Audio Levels: The BTU-3.2 sends commands to the connected Bluetooth device to adjust the playback audio levels, but many devices require that the user make these settings manually. Usually the playback levels for audio streaming, phone calls and *Voice Command* are all stored separately so must be adjusted separately. The first time you stream audio, take a phone call, or use the *Voice Command* feature, use the volume buttons or volume slider menu on the device to adjust the audio level. This only needs to be performed once on the device as these settings are permanently saved in the device.

Bluetooth Voice Command: The Bluetooth *Voice Command* feature allows the user to control their compatible Bluetooth device through voice commands. The *Voice Command* feature is accessible in all radio modes. It is designed to work with Apple Siri®, Google Voice® and Microsoft Cortana® and other Bluetooth voice interfaces. To initiate a *Voice Command*, twist the volume control back and forth twice towards the direction of higher volume or push and hold the optional pushbutton/seek-button. (this is the same motion that was used to open up pairing) Wait for the confirmation tone from the Bluetooth device and then speak the command. For example you can say things like “call home” or “play Bruce Springsteen”. Check with the manual for your Bluetooth device for further information on its support for voice commands.

Bluetooth/USB Streaming Audio: To start playing music from either the Bluetooth or USB interface, twist the volume control back and forth twice towards the direction of lower volume or push and hold the optional pushbutton/seek-button for about 1 second. (you can also use the menus on your Bluetooth device to control the audio) Audio will start playing from the device that has focus as explained above. To toggle between pause and play, repeat the procedure above. When the audio is paused, the FMR-3 status LED will blink slowly. If the audio is paused for more than about 10 seconds, the BTU-3.2 will release the FMR-3 and it will switch back to normal radio operation. If playback is started again, it will continue from where it left off.

For the USB interface, if the BTU-3.2 remains in pause for more than 10 minutes, playback will start from the beginning of the last song rather than from where it left off. Additionally to change the operating mode of the USB interface between random and sequential playback, start by placing the USB interface in pause as described above. To select random playback, twist the tuning control towards the high frequency end of the dial or quickly press the optional pushbutton/seek-button once. To select sequential playback, twist the tuning control towards the low frequency

end of the dial or quickly press the optional pushbutton/seek-button twice. To restart sequential playback, double twist the tuning control towards the low frequency end of the dial or quickly press the optional pushbutton/seek-button twice and hold. A *Voice Assist HD* message will confirm the above settings. The operating mode may also be changed using the FMRConnect™ Mobile App or the FMR Configurator™ Desktop App.

To skip to the next song, twist the tuning control towards the high frequency end of the dial or quickly press the optional pushbutton/seek-button once. To skip to the previous song, twist the tuning control towards the low frequency end of the dial or quickly press the optional pushbutton/seek-button twice. (Hint: when twisting the tuning control, twist it in the desired direction and then back to the starting point. This way the tuner always remains in the same position)

In sequential mode, to skip to the next folder, double twist the tuning control on the radio towards the high frequency end of the dial or quickly press the optional pushbutton/seek-button once and then press and hold. To skip to the previous folder, double twist the tuning control towards the low frequency end of the dial or quickly press the optional pushbutton/seek-button twice and then press and hold.

Hands-free Phone: When a phone call comes in, the FMR-3 will mute the radio and ring through. To accept the call, twist the tuning control towards the high frequency end of the dial or quickly press the optional pushbutton/seek-button once. To reject or end a call, twist the tuning control towards the low frequency end of the dial or quickly press the optional pushbutton/seek-button twice or press the seek button again.

To mute the microphone, twist the volume control back and forth twice towards the direction of lower volume or push and hold the optional pushbutton/seek-button for about 1 second. (you can also use the menus on your Bluetooth device to control the audio) A repeating confirmation tone will be heard on the radio while the call is muted. To toggle between mute and unmuted, repeat the instructions above. When the audio is muted, the FMR-3 status LED will blink slowly. A *Voice Assist HD* message will be heard confirming when the call ends.

For call-waiting, follow the same procedure as above to accept or reject the waiting call. To switch between calls, use the accept call action. To end the active call, use the reject call action. To join the calls, twist the volume control back and forth twice towards the direction of higher volume or push and hold the optional pushbutton/seek-button.

Note: The Bluetooth device can also be controlled using its own menus. (follow manufactures instructions on controlling your device)

Note: For enhanced operation on Town & Country radios, see Quick Start Guide.

USB File Structure: The USB drive must be formatted in FAT12, FAT16 or FAT32 format using a MBR Primary partition. The name of the drive can be anything, so you may want to name them after the type of audio on them, i.e. Rock and Roll, Easy listening, Audio Books, etc.

Audio files must be in standard AAC, MP3, Ogg Vorbis or FLAC format and file names must use the .aac .m4a .mp3 .ogg .flac extensions. Files not conforming to this specification will be ignored. (DRM protected .m4p files are not supported)

Each folder, including the root, can contain up to 250 files and an unlimited number of folders. (2250 folders and 65534 files maximum) In this manner the root folders could use the artist names with the subfolders named for each album, or the root folders could be name for music genres, etc.

Since indexing the drive takes a bit of time, the BTU-3.2 will start playing a song while indexing. Non-audio files will slow the indexing process down and should be avoided. If the drive must be used for non-audio files, the audio files can go into a folder named ~Music~. The BTU-3.2 will then only look in this folder, speeding up the indexing process.

The BTU-3.2 will place three files on the drive, ~AD_USB0.TXT, ~AD_USB1.TXT and ~AD_FMR.CFG with the audio files. These files are used by the BTU-3.2 for housekeeping and should not be modified. (these files do contain the version level of the BTU-3.2)

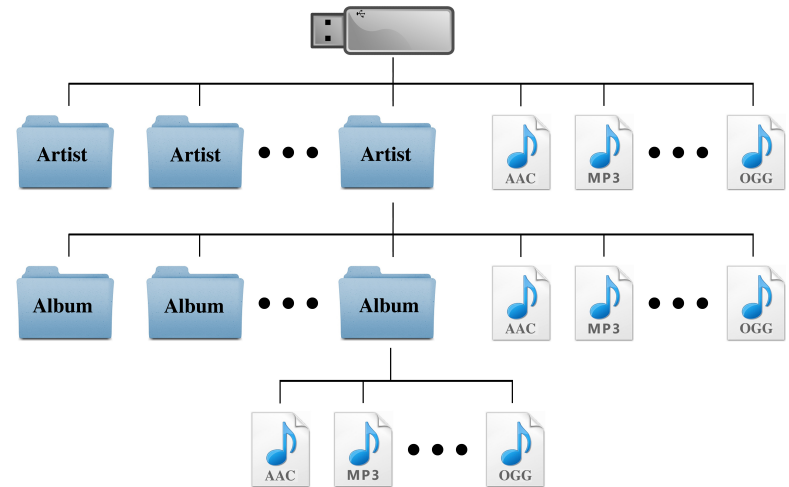

Suggested USB File Layout

USB Charging: The BTU-3.2 USB port supports SDP, CDP and DCP charging modes up to 2.1A. It is compatible with proprietary modes like Apple® 1A/2A and BlackBerry®. The BTU-3.2 will continue charging even when the radio is off as long as the vehicle power is on.